

# High-voltage amplifier uses simplified circuit

Jui-I Tsai, Jun-Ming Shieh, Tai-Shan Liao, and Ching-Cheng Teng, National Chiao Tung University, Taiwan

**M**ANY SCIENTIFIC INSTRUMENTS and sensors need ac high-voltage drive. High-voltage drive is useful for driving electrodes in many applications. The challenge is to boost the output of a conventional op amp to high voltages. Available ac high-voltage amplifier modules are limited to approximately 1200V p-p. This Design Idea presents a simplified ac high-voltage amplifier that uses complementary, cascaded NMOS and PMOS transistors (Figure 1). The OP07 op amp has low input-offset voltage, low input-bias current, and high open-loop gain. These attributes make this op amp useful for high-gain instrumentation applications. In addition, the OP07 features

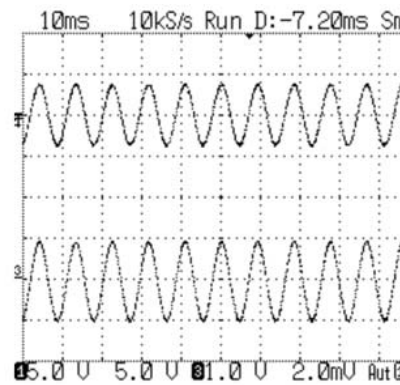

**Figure 2** The sinusoidal input is 8V p-p (top trace), and output is 1800V p-p (bottom trace).

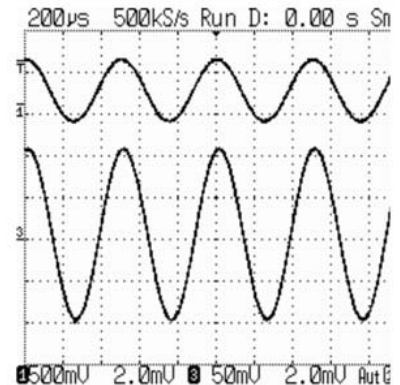

**Figure 3** The input is 750 mV p-p (top trace), and the output is 200V p-p (bottom trace).

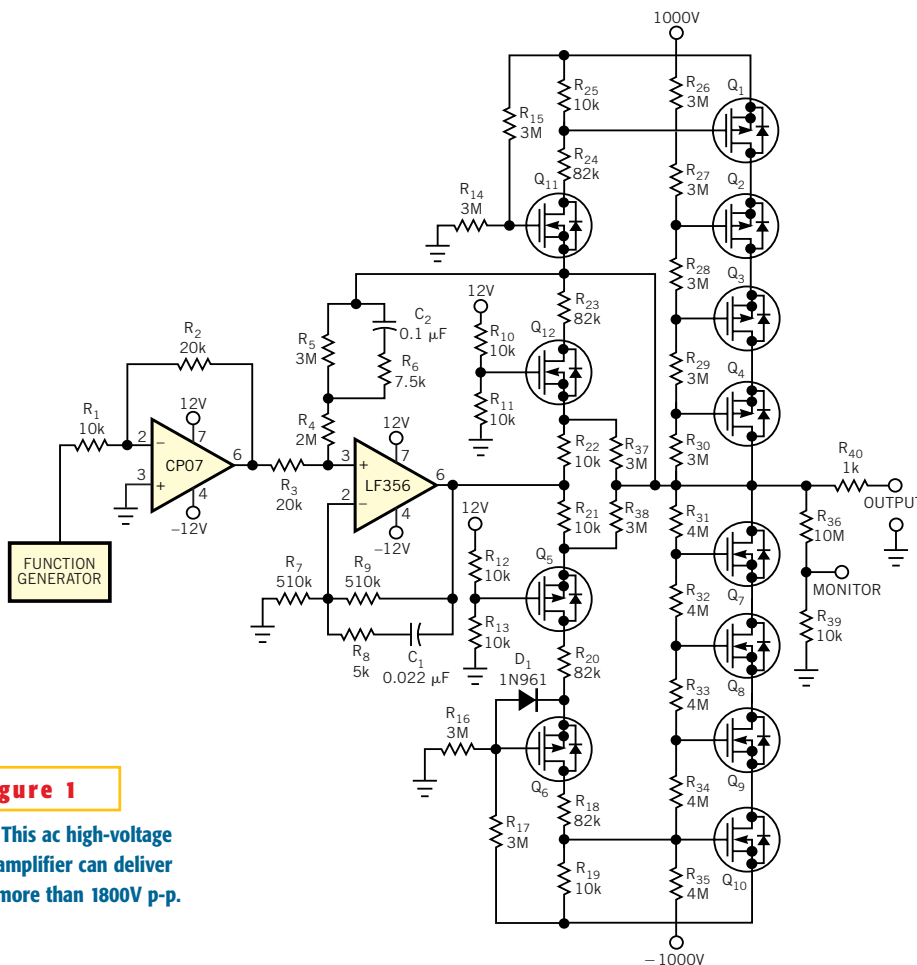

**Figure 1** This ac high-voltage amplifier can deliver more than 1800V p-p.

excellent stability of offsets and gain over time and temperature. The ac gain of the LM356 stage, which  $R_3$ ,  $R_4$ ,  $R_7$ , and  $R_9$  determine, is approximately 100.

The high-voltage MTP2P50E p-channel MOSFET has maximum drain-to-source- and gate-to-drain-voltage ratings of 500V. The high-voltage BUK456800B n-channel MOSFET has maximum drain-to-source- and gate-to-drain-voltage ratings of 800V.  $Q_1$  through  $Q_6$  are PMOS transistors, and  $Q_7$  through  $Q_{12}$  are NMOS devices. These FETs are well-suited for high-voltage cascade circuits. They connect symmetrically in series to increase their overall breakdown voltage for power applications. The bias-voltage circuits comprise separate biasing-resistor pairs  $R_{10}$  to  $R_{13}$  and  $R_{14}$  to  $R_{17}$ ; the result is a symmetrical output of the high-voltage amplifier. Figure 2 shows a sinusoidal input of 8V p-p at 100 Hz and an output of 1800V p-p. Figure 3 shows a sinusoidal input of 750 mV p-p at 2 kHz and an output of 200V p-p. The total power bandwidth of the circuit is approximately 200 kHz. □